

move^{xx}

smart electric tugs

EN



Technical datasheet

TT1500-S

M030



» move your work **easier**

TECHNICAL DATA TT1500-S M030

According to VDI 2198 in Metric units.

Characteristics	1.1	Manufacturer		Movexx International B.V.	
	1.2	Manufacturer's type designation		TT1500-S M030	
	1.3	Drive		Electric with LiFePo ₄ battery	
	1.4	Operator type		Pedestrian	
	1.5*	Rated capacity/rated load	Q [t]	1.5	
	1.7**	Rated drawbar pull	F [N]	492	
	1.9	Wheelbase	y [mm]	712	
Wt	2.1	Weight incl. battery	kg	230	
	2.3	Axle loading, without load	front/rear	kg	94/136
Tyres/Chassis	3.1	Tyres	front/rear	Solid Rubber	
	3.2	Tyres size	front	mm	125x35
	3.3	Tyres size	rear	mm	250x84
	3.5	Wheels, number (x = driven)	front/rear		1/x2
	3.6	Tread	front/rear	b ₁₀ /b ₁₁ [mm]	-/405
Dimensions	4.9	Tiller height	min-max	h ₁₄ [mm]	950/1065/1145
	4.12	Tow coupling height	min-max	h ₁₀ [mm]	85-275
	4.19	Overall length		l ₁ [mm]	1230
	4.21	Overall width		b ₁ [mm]	495
	4.32	Ground clearance, center of wheel base		m ₂ [mm]	50
Performance	5.1	Travel speeds forwards	with/without load	km/h	4/4
	5.1.1	Travel speed backwards	with/without load	km/h	4/4
	5.5**	Max drawbar pull (S2 = 60 min)	with load	N	492
	5.6**	Max drawbar pull (S2 = 5 min)	with load	N	1050
	5.8*	Maximum slope (5 min)	with/without load	%	0/15
	5.9	Acceleration	with/without load	s	10/8
	5.10	Service brake			Electromagnetic
Drive	6.1	Drive motor output (S2 = 60 min)		kW	0.6
	6.4	Battery voltage/nominal capacity		V/Ah	24/20
	6.5	Battery weight +/- 5%		kg	8.5
Other	8.1	Type of drive unit			DC
	10.7	Sound level at operator's ear		dB(A)	<65

* The maximum payload is affected by the type of slope, operating time and floor type. See the graphic below for an indication of the allowable slope to load ratio (depending on slope surface/wheel type/machine weight).

** The maximum drawbar load on the hook [N] is determined by the engine power of the machine but is affected by the type of wheels of the machine and of the towed trolley/load, the type of surface and the driveable weight of the machine.

*** All values in this table have a tolerance of +/- 5%.

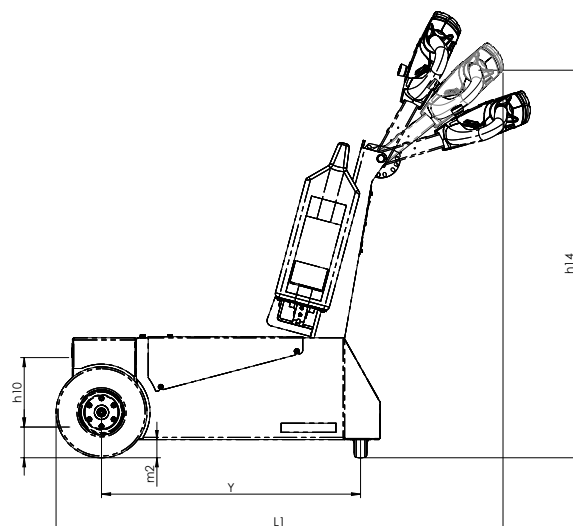
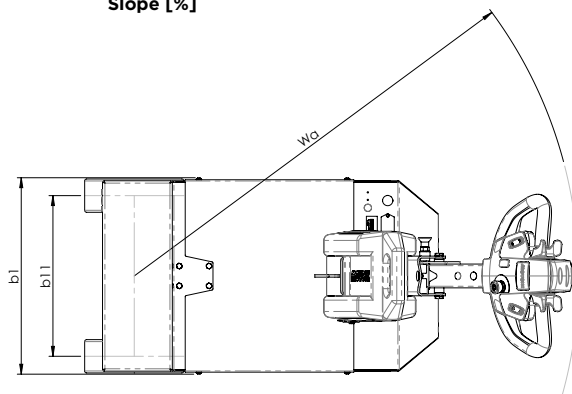
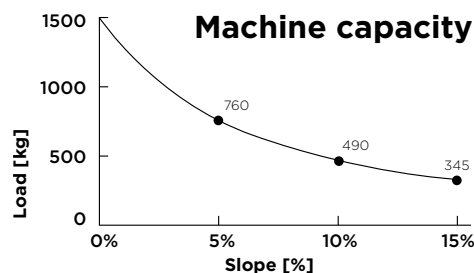

TECHNICAL DATA TT1500-S M030

According to VDI 2198 in Imperial units.

Characteristics	1.1	Manufacturer		Movexx International B.V.
	1.2	Manufacturer's type designation		TT1500-S M030
	1.3	Drive		Electric with LiFePo ₄ battery
	1.4	Operator type		Pedestrian
	1.5*	Rated capacity/rated load	Q [tn(US)]	1.7
	1.7**	Rated drawbar pull	F [lbf]	110
	1.9	Wheelbase	y [in]	28
Wt	2.1	Weight incl. battery	lb	507
	2.3	Axle loading, without load	front/rear lb	207/300
Tyres/Chassis	3.1	Tyres	front/rear	Solid Rubber
	3.2	Tyres size	front	in 4.9x1.4
	3.3	Tyres size	rear	in 9.9x3.3
	3.5	Wheels, number (x = driven)	front/rear	1/x2
	3.6	Tread	front/rear	b ₁₀ /b ₁₁ [in] -/16
	Dimensions	4.9	Tiller height	min-max
4.12		Tow coupling height	min-max	h ₁₀ [in] 3.5-11
4.19		Overall length		l ₁ [in] 48.5
4.21		Overall width		b ₁ [in] 19.5
4.32		Ground clearance, center of wheel base		m ₂ [in] 2
4.35		Turning radius		Wa [in] 44
Performance	5.1	Travel speeds forwards	with/without load	mph 2.5/2.5
	5.1.1	Travel speed backwards	with/without load	mph 2.5/2.5
	5.5**	Max drawbar pull (S2 = 60 min)	with load	lbf 110
	5.6**	Max drawbar pull (S2 = 5 min)	with load	lbf 236
	5.8*	Maximum slope (5 min)	with/without load	0/15
	5.9	Acceleration	with/without load	10/8
	5.10	Service brake		Electromagnetic
Drive	6.1	Drive motor output (S2 = 60 min)	hp	0.8
	6.4	Battery voltage/nominal capacity		24/20
	6.5	Battery weight +/- 5%	lb	18.5
Other	8.1	Type of drive unit		DC
	10.7	Sound level at operator's ear		<65

* The maximum payload is affected by the type of slope, operating time and floor type. See the graphic below for an indication of the allowable slope to load ratio (depending on slope surface/wheel type/machine weight).

** The maximum drawbar load on the hook [lbf] is determined by the engine power of the machine but is affected by the type of wheels of the machine and of the towed trolley/load, the type of surface and the driveable weight of the machine.

*** All values in this table have a tolerance of +/- 5%.

