



## Technical datasheet

# TT1500-T-Cleanroom

M010

# TECHNICAL DATA TT1500-T-Cleanroom M010

According to VDI 2198 in Metric units.

<b>Characteristics</b>	1.1	Manufacturer		Movexx International B.V.	
	1.2	Manufacturer's type designation		TT1500-T-Cleanroom M010	
	1.3	Drive		Electric with AGM-VRLA battery	
	1.4	Operator type		Tilting	
	1.5*	Rated capacity/rated load	Q [t]	1.5	
	1.7**	Rated drawbar pull	F [N]	490	
<b>Wt</b>	2.1	Weight incl. battery	kg	105	
	2.3	Axle load with load	front/rear	kg	123
<b>Tyres/Chassis</b>	3.1	Tyres		Solid Rubber/Non-Marking	
	3.2	Tyres size	front	mm	250x84
	3.4	Auxiliary wheels size		mm	125
	3.5	Wheels, number (x = driven)	front/rear		-/x2
	3.6	Tread	front/rear	$b_{10}/b_{11}$ [mm]	-/426
	<b>Dimensions</b>	4.9	Tiller height	min./max.	$h_{14}$ [mm]
4.12		Tow coupling height		$h_{10}$ [mm]	120-260
4.19		Total length		$l_1$ [mm]	1052
4.21		Total width		$b_1$ [mm]	511
4.32		Ground clearance, center of wheel base		$m_2$ [mm]	37
4.35		Turning radius		$W_a$ [mm]	757
<b>Performance</b>	5.1	Travel speeds	with/without load	km/h	4/4
	5.1.1	Travel speed backwards	with/without load	km/h	4/4
	5.5**	Max drawbar pull (S2 = 60 min)	with/without load	N	490
	5.6**	Max drawbar pull (S2 = 5 min)	with/without load	N	980
	5.8*	Maximum slope (5 min)	with/without load	%	0/15
	5.9	Acceleration	with/without load	s	8/6
	5.10	Service brake			Electromagnetic
<b>Drive</b>	6.1	Drive motor output (S2 = 60 min)	kW	0.6	
	6.4	Battery voltage/rated capacity	V/Ah	24/20	
	6.5	Battery weight +/- 5%	kg	8.5	
<b>Other</b>	8.1	Drive control		DC	
	10.7	Sound level at operator's ear	dB(A)	<65	

\* The maximum payload is affected by the type of slope, operating time and floor type. See the graphic below for an indication of the allowable slope to load ratio (depending on slope surface/wheel type/machine weight).

\*\* The maximum drawbar load on the hook [N] is determined by the engine power of the machine but is affected by the type of wheels of the machine and of the towed trolley/load, the type of surface and the driveable weight of the machine.

\*\*\* All values in this table have a tolerance of +/- 5%.

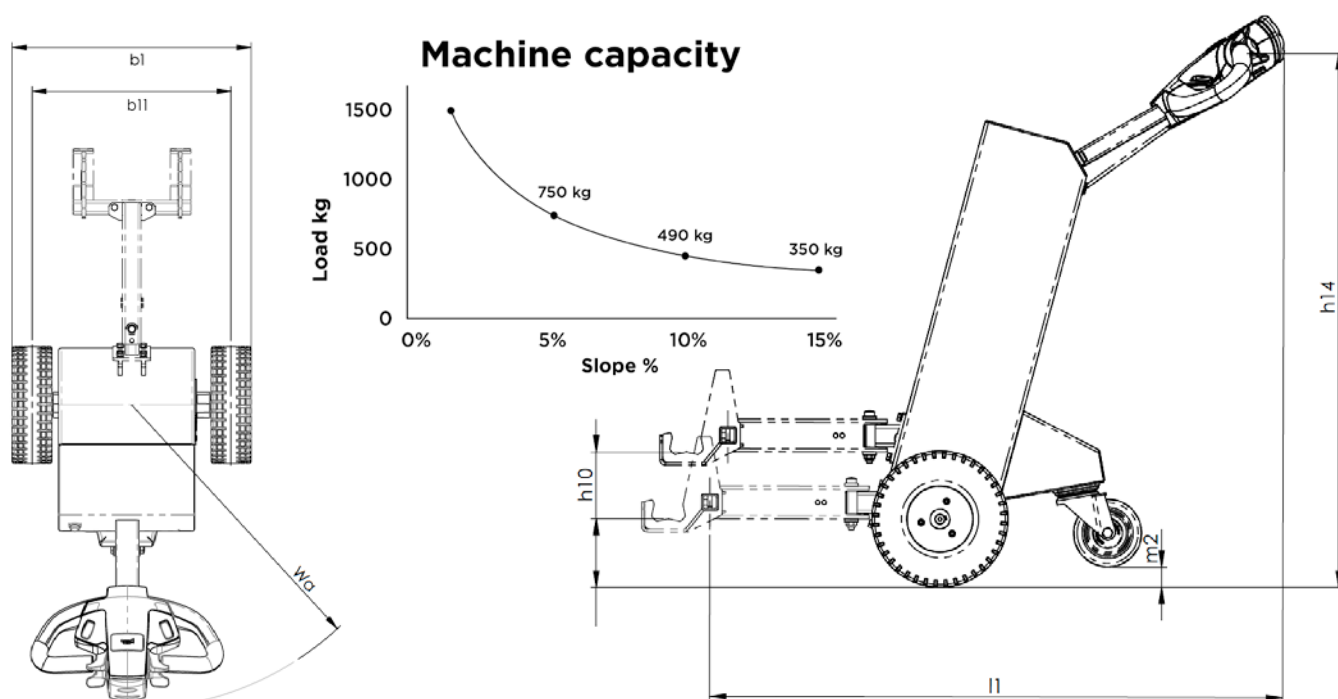

All Images of products shown in this datasheet are indicative only. The actual products may differ from the displayed image. No rights can therefore be derived from the images shown.

# TECHNICAL DATA TT1500-T-Cleanroom M010

According to VDI 2198 in Imperial units.

<b>Characteristics</b>	<b>1.1</b>	Manufacturer		Movexx International B.V.
	<b>1.2</b>	Manufacturer's type designation		TT1500-T-Cleanroom M010
	<b>1.3</b>	Drive		Electric with AGM-VRLA battery
	<b>1.4</b>	Operator type		Tilting
	<b>1.5*</b>	Rated capacity/rated load	Q [tn(US)]	1.6
	<b>1.7**</b>	Rated drawbar pull	F [lbf]	110
<b>Wt</b>	<b>2.1</b>	Weight incl. battery	lb	232
	<b>2.3</b>	Axle load with load	front/rear	lb 271
<b>Tyres/Chassis</b>	<b>3.1</b>	Tyres		Solid Rubber/Non-Marking
	<b>3.2</b>	Tyres size	front	in 9.8x3.3
	<b>3.4</b>	Auxiliary wheels size		in 5
	<b>3.5</b>	Wheels, number (x = driven)	front/rear	-/x2
	<b>3.6</b>	Tread	front/rear	$b_{10}/b_{11}$ [in] -/16.5
		<b>4.9</b>	Tiller height	min./max.
	<b>4.12</b>	Tow coupling height		$h_{10}$ [in] 4.5-10.5
	<b>4.19</b>	Total length		$l_1$ [in] 41.5
	<b>4.21</b>	Total width		$b_1$ [in] 20
	<b>4.32</b>	Ground clearance, center of wheel base	$m_2$ [in]	1.5
	<b>4.35</b>	Turning radius	$W_a$ [in]	30
<b>Performance</b>	<b>5.1</b>	Travel speeds	with/without load	mph 2.5/2.5
	<b>5.1.1</b>	Travel speed backwards	with/without load	mph 2.5/2.5
	<b>5.5**</b>	Max drawbar pull (S2 = 60 min)	with/without load	lbf 110
	<b>5.6**</b>	Max drawbar pull (S2 = 5 min)	with/without load	lbf 220
	<b>5.8*</b>	Maximum slope (5 min)	with/without load	% 0/15
	<b>5.9</b>	Acceleration	with/without load	s 8/6
	<b>5.10</b>	Service brake		Electromagnetic
<b>Drive</b>	<b>6.1</b>	Drive motor output (S2 = 60 min)	hp	0.80
	<b>6.4</b>	Battery voltage/rated capacity	V/Ah	24/20
	<b>6.5</b>	Battery weight +/- 5%	lb	18.5
<b>Other</b>	<b>8.1</b>	Drive control		DC
	<b>10.7</b>	Sound level at operator's ear	dB(A)	<65

\* The maximum payload is affected by the type of slope, operating time and floor type. See the graphic below for an indication of the allowable slope to load ratio (depending on slope surface/wheel type/machine weight).

\*\* The maximum drawbar load on the hook [lbf] is determined by the engine power of the machine but is affected by the type of wheels of the machine and of the towed trolley/load, the type of surface and the driveable weight of the machine.

\*\*\* All values in this table have a tolerance of +/- 5%.

