



**Technical datasheet**  
**TT2500-S-Cleanroom**

M020

# TECHNICAL DATA TT2500-S-Cleanroom M020

According to VDI 2198 in Metric units.

<b>Characteristics</b>	<b>1.1</b>	Manufacturer		Movexx International B.V.	
	<b>1.2</b>	Manufacturer's type designation		TT2500-S-Clean Room M020	
	<b>1.3</b>	Drive		Electric with LiFePo <sub>4</sub> battery	
	<b>1.4</b>	Operator type		Pedestrian	
	<b>1.5*</b>	Rated capacity/rated load	Q [t]	2.5	
	<b>1.7**</b>	Rated drawbar pull	F [N]	490	
<b>1.9</b>	Wheelbase	y [mm]	382		
<b>Wt</b>	<b>2.1</b>	Weight incl. battery	kg	198	
	<b>2.3</b>	Axle load with load	front/rear	kg	94/104
<b>Tyres/Chassis</b>	<b>3.1</b>	Tyres		Non-Marking/Solid Rubber	
	<b>3.2</b>	Tyres size	front	mm	125x35
	<b>3.3</b>	Tyres size	rear	mm	250x84
	<b>3.5</b>	Wheels, number (x = driven)	front/rear		1/x2
	<b>3.6</b>	Tread	front/rear	b <sub>10</sub> / b <sub>11</sub> [mm]	-/428
<b>Dimensions</b>	<b>4.9</b>	Tiller height	min./max.	h <sub>14</sub> [mm]	1004
	<b>4.12</b>	Tow coupling height		h <sub>10</sub> [mm]	110-300
	<b>4.19</b>	Total length		l <sub>1</sub> [mm]	1150
	<b>4.21</b>	Total width		b <sub>1</sub> [mm]	513
	<b>4.32</b>	Ground clearance, center of wheel base		m <sub>2</sub> [mm]	65
<b>4.35</b>	Turning radius		Wa [mm]	1040	
<b>Performance</b>	<b>5.1</b>	Travel speeds	with/without load	km/h	4/4.5
	<b>5.1.1</b>	Travel speed backwards	with/without load	km/h	4/4.5
	<b>5.5**</b>	Max drawbar pull (S2 = 40 min)	with/without load	N	490
	<b>5.6**</b>	Max drawbar pull (S2 = 5 min)	with/without load	N	1225
	<b>5.8*</b>	Maximum slope (5 min)	with/without load	%	0/15
	<b>5.9</b>	Acceleration	with/without load	s	10/8
	<b>5.10</b>	Service brake			Electromagnetic
<b>Drive</b>	<b>6.1</b>	Drive motor output (S2 = 60 min)		kW	0.6
	<b>6.4</b>	Battery voltage/rated capacity		V/Ah	24/80
	<b>6.5</b>	Battery weight +/- 5%		kg	47
<b>Other</b>	<b>8.1</b>	Drive control			DC
	<b>10.7</b>	Sound level at operator's ear		dB(A)	<68

\* The maximum payload is affected by the type of slope, operating time and floor type. See the graphic below for an indication of the allowable slope to load ratio (depending on slope surface/wheel type/machine weight).

\*\* The maximum drawbar load on the hook [N] is determined by the engine power of the machine but is affected by the type of wheels of the machine and of the towed trolley/load, the type of surface and the driveable weight of the machine.

\*\*\* All values in this table have a tolerance of +/- 5%.

## Machine capacity

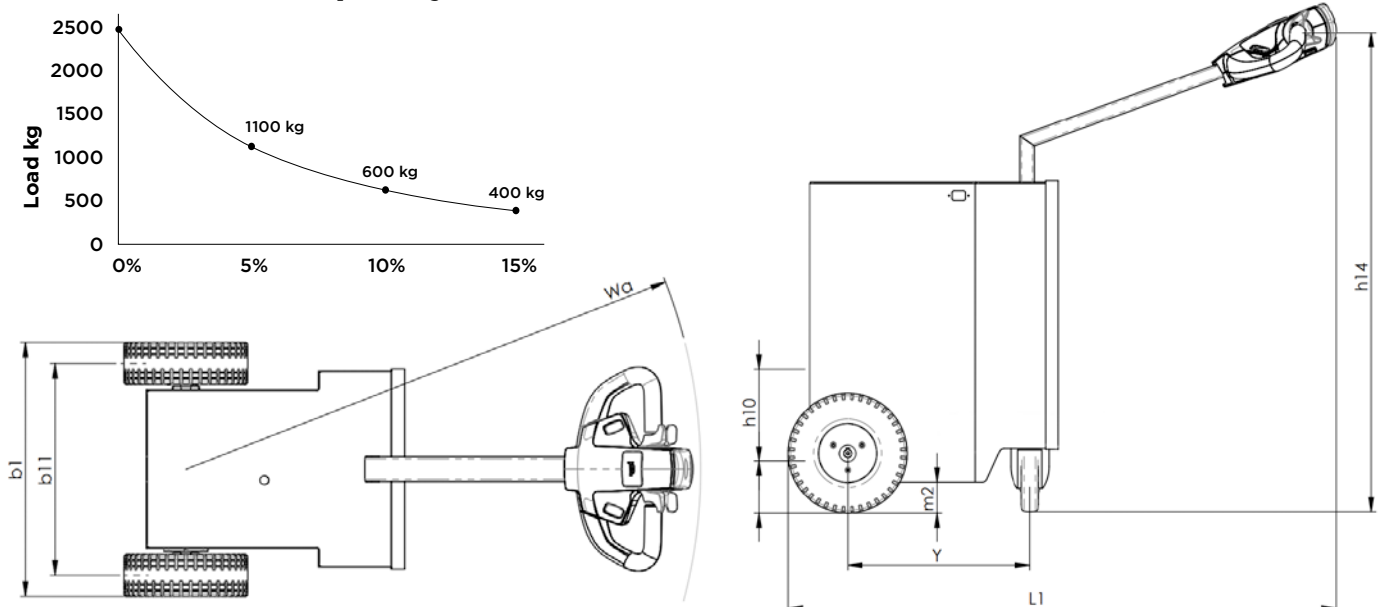

All Images of products shown in this datasheet are indicative only. The actual products may differ from the displayed image. No rights can therefore be derived from the images shown.

# TECHNICAL DATA TT2500-S-Cleanroom M020

According to VDI 2198 in Imperial units.

Characteristics	1.1	Manufacturer		Movexx International B.V.	
	1.2	Manufacturer's type designation		TT2500-S-Clean Room M020	
	1.3	Drive		Electric with LiFePo <sub>4</sub> battery	
	1.4	Operator type		Pedestrian	
	1.5*	Rated capacity/rated load	Q [tn(US)]	2.8	
	1.7**	Rated drawbar pull	F [lbf]	110	
1.9	Wheelbase	y [in]	15		
Wt	2.1	Weight incl. battery	lb	436	
	2.3	Axle load with load	front/rear	lb	207/229
Tyres/Chassis	3.1	Tyres		Non-Marking/Solid Rubber	
	3.2	Tyres size	front	in	4.9x1.3
	3.3	Tyres size	rear	in	9.8x3.3
	3.5	Wheels, number (x = driven)	front/rear		1/x2
	3.6	Tread	front/rear	b <sub>10</sub> / b <sub>11</sub> [in]	-/17
Dimensions	4.9	Tiller height	min./max.	h <sub>14</sub> [in]	39.5
	4.12	Tow coupling height		h <sub>10</sub> [in]	4.5-12
	4.19	Total length		l <sub>1</sub> [in]	45
	4.21	Total width		b <sub>1</sub> [in]	20
	4.32	Ground clearance, center of wheel base		m <sub>2</sub> [in]	2.5
4.35	Turning radius		Wa [in]	41	
Performance	5.1	Travel speeds	with/without load	mph	2.5/2.8
	5.1.1	Travel speed backwards	with/without load	mph	2.5/2.8
	5.5**	Max drawbar pull (S2 = 40 min)	with/without load	lbf	110
	5.6**	Max drawbar pull (S2 = 5 min)	with/without load	lbf	275
	5.8*	Maximum slope (5 min)	with/without load	%	0/15
	5.9	Acceleration	with/without load	s	10/8
	5.10	Service brake			Electromagnetic
Drive	6.1	Drive motor output (S2 = 60 min)		hp	0.80
	6.4	Battery voltage/rated capacity		V/Ah	24/80
	6.5	Battery weight +/- 5%		lb	104
Other	8.1	Drive control			DC
	10.7	Sound level at operator's ear		dB(A)	<68

\* The maximum payload is affected by the type of slope, operating time and floor type. See the graphic below for an indication of the allowable slope to load ratio (depending on slope surface/wheel type/machine weight).

\*\* The maximum drawbar load on the hook [lbf] is determined by the engine power of the machine but is affected by the type of wheels of the machine and of the towed trolley/load, the type of surface and the driveable weight of the machine.

\*\*\* All values in this table have a tolerance of +/- 5%.

## Machine capacity

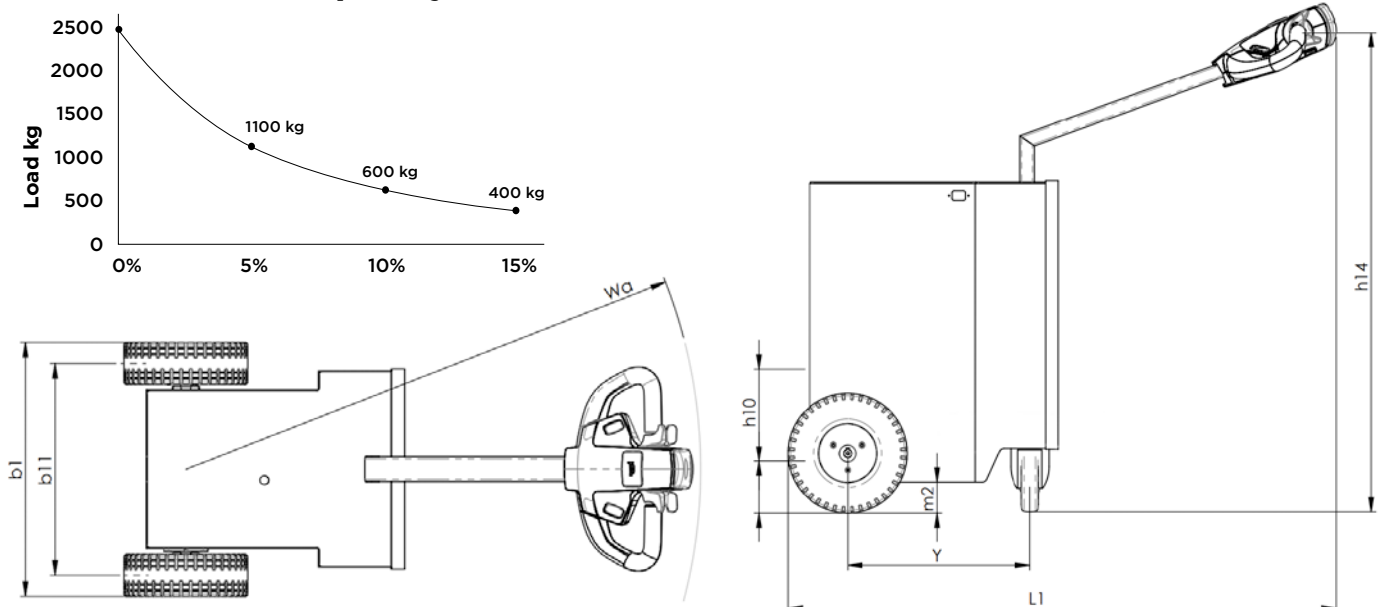

All Images of products shown in this datasheet are indicative only. The actual products may differ from the displayed image. No rights can therefore be derived from the images shown.