

# moveXX

smart electric tugs

EN



## Technical datasheet

# TT3500-S-Push

M070



» move your work easier

# TECHNICAL DATA TT3500-S-Push M070

According to VDI 2198 in Metric units.

<b>Characteristics</b>	1.1	Manufacturer		Movexx International B.V.	
	1.2	Manufacturer's type designation		TT3500-S-Push M070	
	1.3	Drive		Electric w. lead acid battery	
	1.4	Operator type		Pedestrian	
	1.5*	Rated capacity/rated load	Q [t]	3.5	
	1.7**	Rated drawbar pull	F [N]	492	
	1.9	Wheelbase	y [mm]	690	
<b>Wt</b>	2.1	Weight incl. battery	kg	300	
	2.3	Axle load without load	front/rear	kg	171/129
<b>Tyres/Chassis</b>	3.1	Tyres		Solid Rubber	
	3.2	Tyres size	front	mm	125x50
	3.3	Tyres size	rear	mm	250x84
	3.5	Wheels, number (x = driven)	front/rear		1/x2
	3.6	Tread	front/rear	$b_{10}$ [mm]	-/403
	<b>Dimensions</b>	4.9	Tiller height	min./max.	$h_{14}$ [mm]
4.12		Tow coupling height		$h_{10}$ - $h_{11}$ [mm]	90-280
4.19		Total length		$l_1$ [mm]	1145
4.21		Total width		$b_1$ [mm]	511
4.32		Ground clearance, center of wheel base		$m_2$ [mm]	60
4.35		Turning radius		$W_a$ [mm]	1143
<b>Performance</b>	5.1	Travel speeds	with/without load	km/u	2.5/4.5
	5.1.1	Travel speed backwards	with/without load	km/u	2.5/2.5
	5.5**	Max drawbar pull (S2 = 60 min)	with/without load	N	490
	5.6**	Max drawbar pull (S2 = 5 min)	with/without load	N	1230
	5.8*	Maximum slope (5 min)	with/without load	%	0/15
	5.9	Acceleration	with/without load	s	11/9
	5.10	Service brake			Electromagnetic
<b>Drive</b>	6.1	Drive motor output (S2 = 60 min)		kW	0.6
	6.4	Battery voltage/rated capacity		V/Ah	24/80
	6.5	Battery weight +/- 5%		kg	54
<b>Other</b>	8.1	Drive control			DC
	10.7	Sound level at operator's ear		dB(A)	<65

\* The maximum payload is affected by the type of slope, operating time and floor type. See the graphic below for an indication of the allowable slope to load ratio (depending on slope surface/wheel type/machine weight).

\*\* The maximum drawbar load on the hook [N] is determined by the engine power of the machine but is affected by the type of wheels of the machine and of the towed trolley/load, the type of surface and the driveable weight of the machine.

\*\*\* All values in this table have a tolerance of +/- 5%.

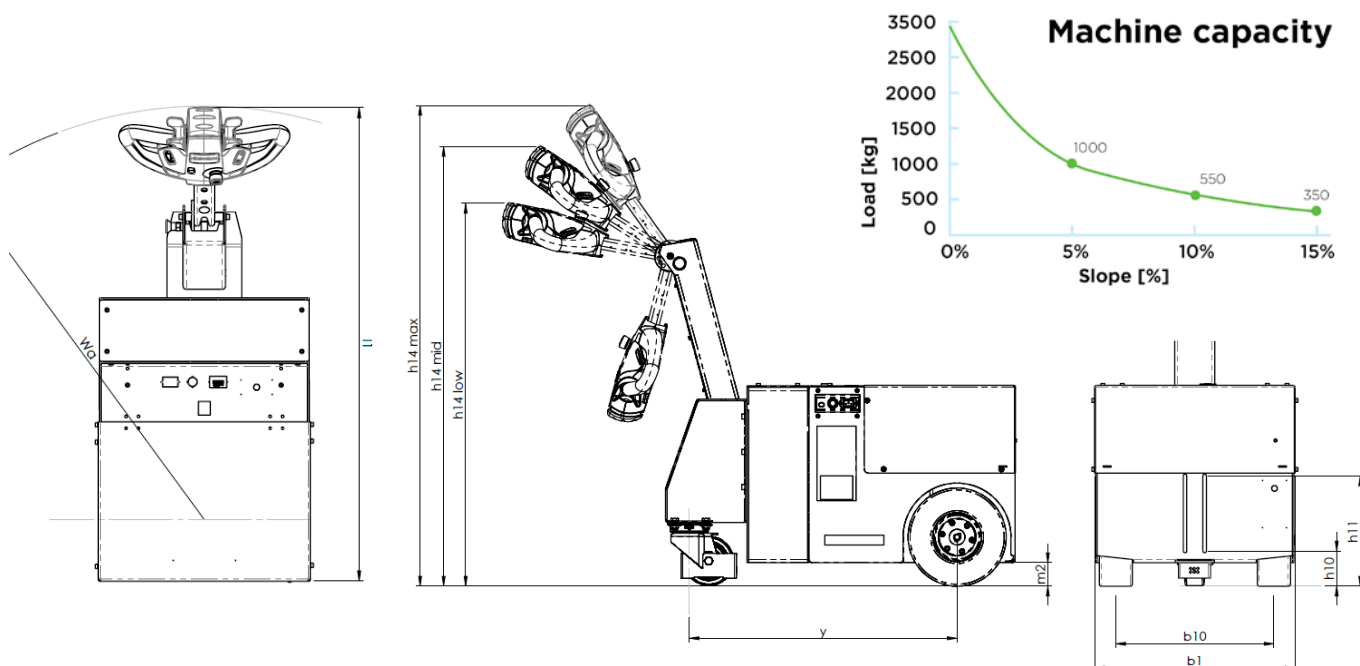

# TECHNICAL DATA TT2500-S-Push M070

According to VDI 2198 in Imperial units.

<b>Characteristics</b>	1.1	Manufacturer		Movexx International B.V.
	1.2	Manufacturer's type designation		TT3500-S-Push M070
	1.3	Drive		Electric w. lead acid battery
	1.4	Operator type		Pedestrian
	1.5*	Rated capacity/rated load	Q [tn(US)]	3.9
	1.7**	Rated drawbar pull	F [lbf]	110
	1.9	Wheelbase	y [in]	27.2
<b>Wt</b>	2.1	Weight incl. battery	lb	661
	2.3	Axle load without load	front/rear lb	377/284
<b>Tyres/Chassis</b>	3.1	Tyres		Solid Rubber
	3.2	Tyres size	front in	4.9x2.0
	3.3	Tyres size	rear in	9.8x3.3
	3.5	Wheels, number (x = driven)	front/rear	1/x2
	3.6	Tread	front/rear $b_{10}$ [in]	-/16
	<b>Dimensions</b>	4.9	Tiller height	min./max. $h_{14}$ [in]
4.12		Tow coupling height	$h_{10}$ - $h_{11}$ [in]	3.5-11.0
4.19		Total length	$l_1$ [in]	45
4.21		Total width	$b_1$ [in]	20
4.32		Ground clearance, center of wheel base	$m_2$ [in]	2.4
4.35		Turning radius	$W_a$ [in]	45
<b>Performance</b>	5.1	Travel speeds	with/without load mph	1.6/2.8
	5.1.1	Travel speed backwards	with/without load mph	1.6/1.6
	5.5**	Max drawbar pull (S2 = 60 min)	with/without load lbf	110
	5.6**	Max drawbar pull (S2 = 5 min)	with/without load lbf	277
	5.8*	Maximum slope (5 min)	with/without load %	0/15
	5.9	Acceleration	with/without load s	11/9
	5.10	Service brake		Electromagnetic
<b>Drive</b>	6.1	Drive motor output (S2 = 60 min)	hp	0.8
	6.4	Battery voltage/rated capacity	V/Ah	24/80
	6.5	Battery weight +/- 5%	lb	119
<b>Other</b>	8.1	Drive control		DC
	10.7	Sound level at operator's ear	dB(A)	<65

\* The maximum payload is affected by the type of slope, operating time and floor type. See the graphic below for an indication of the allowable slope to load ratio (depending on slope surface/wheel type/machine weight).

\*\* The maximum drawbar load on the hook [lbf] is determined by the engine power of the machine but is affected by the type of wheels of the machine and of the towed trolley/load, the type of surface and the driveable weight of the machine.

\*\*\* All values in this table have a tolerance of +/- 5%.

