

Flexible and powerful walk behind electric stacker with forks installed between the support spars and the operator. Ideal for handling non-standard loads



The 716 – 720 BLK ac walk behind forklift trucks are specially designed and constructed for special applications. The widened spars allow lowering the forks down to ground level, rendering the forklift ideal for various types of loads.

Frame

Made of bended sheet metal to minimise any tensions induced by welds, ensuring maximum mechanical resistance over time. The configuration with three support points offers unique lateral stability. The highly visible masts and the central tiller ensure optimal visibility for load storage, picking and transport. The battery compartment cover is hinged, facilitating battery top-up and daily and periodical maintenance operations. Particular attention was paid to simplify the access to mechanical parts so as to minimise the routine maintenance costs.

Masts

The OMG masts are made of cold extruded profiles ensuring high resistance to bending and twisting. The lift cylinders are installed outside of the

mast profiles and the chains are protected to ensure perfect visibility and maximum safety. Available in simplex, duplex and triplex version with wide free lift and nominal capacities of 1,600 and 2,000 kg.

Hydraulic functions

The 3kW powerful and silent lift motor with high torque ration offers high performance with low power consumption. The pumps are highly efficient and very quiet. The mini joystick installed on the tiller (finger touch) allows the operator to lift and lower the forks without releasing the tiller.

Drive

Powerful and reliable AC traction motor, capable of meeting even the most demanding requests in terms of performance, under any conditions. Travel

speed controlled directly by the throttle installed on the tiller.

Electronic system

The OMG machines are fitted with AC control with energy recovery, that can be enabled by:

- releasing the drive control on the tiller
- reversing the running direction also using the drive control on the tiller

From this control, the operator can manage all truck's functions and carry out unlimited adjustments for performance optimisation, adapting the machine to any application, while ensuring silent operation and low power consumption at the same time.

The configuration with three support points provides optimal lateral stability, ensuring maximum safety and comfort during load picking and storage. The mini joystick (finger touch) allows the operator to control the truck by simply moving his finger along the tiller, ensuring precise and smooth load lifting and lowering, without taking his hands off the tiller. The hydraulic motor with fluid adjustment system reduces the noise, ensuring at the same time smooth and precise load lifting. Enhanced lifting and lowering speed for faster operations. Side cylinders fitted with silent blocks to prevent any kickbacks that might affect the stability of the load during forks lowering.



Widened base, ranging from 880 to 1,300 mm and beyond (on request) that can house pallet spars, standard and special containers. Central drive wheel, suitable even for irregular floors



The forklift trucks in the 716 - 720 BLK ac range are fitted with traction batteries of up to 375 Ah. Readily accessible battery compartment for fast and simple battery check and top-up. With the wo-wa battery charger installed on-board (optional) you can recharge your truck from any socket. The electronic control comes with IP 65 protection rating and is waterproof and dustproof. The tiller head can also be manufactured with IP55 protection rating for protection against dust and water (standard feature for cold store versions).



Accessories and special features

total free lift for duplex column total free lift for triplex column protection for cold storage supertrack drive wheel polyurethane drive wheel low speed push-button with tiller in vertical position servo-assisted tiller version with spars exceeding 880 mm 3rd hydraulic way with built-in shifter	<div style="width: 15px; height: 15px; background-color: black; margin: 0 auto;"></div> <div style="width: 15px; height: 15px; background-color: #f4a460; margin: 0 auto;"></div> <div style="width: 15px; height: 15px; background-color: black; margin: 0 auto;"></div> <div style="width: 15px; height: 15px; background-color: #f4a460; margin: 0 auto;"></div> <div style="width: 15px; height: 15px; background-color: #f4a460; margin: 0 auto;"></div> <div style="width: 15px; height: 15px; background-color: #f4a460; margin: 0 auto;"></div> <div style="width: 15px; height: 15px; background-color: black; margin: 0 auto;"></div> <div style="width: 15px; height: 15px; background-color: black; margin: 0 auto;"></div> <div style="width: 15px; height: 15px; background-color: black; margin: 0 auto;"></div>	access keypad with pin code anti roll-back device electronic speed control electronic braking system electromagnetic parking brake voltmeter-timer, auto-lock function when 80% of the battery capacity is discharged 24V 35A current rectifier on-board automatic battery filling system	<div style="width: 15px; height: 15px; background-color: black; margin: 0 auto;"></div> <div style="width: 15px; height: 15px; background-color: #f4a460; margin: 0 auto;"></div> <div style="width: 15px; height: 15px; background-color: #f4a460; margin: 0 auto;"></div> <div style="width: 15px; height: 15px; background-color: #f4a460; margin: 0 auto;"></div> <div style="width: 15px; height: 15px; background-color: #f4a460; margin: 0 auto;"></div> <div style="width: 15px; height: 15px; background-color: #f4a460; margin: 0 auto;"></div> <div style="width: 15px; height: 15px; background-color: black; margin: 0 auto;"></div> <div style="width: 15px; height: 15px; background-color: black; margin: 0 auto;"></div>
standard 		optional 	

Standard masts						716 BLK ac	720 BLK ac	
Description		Lowered mast height	Forks stroke	Total lifting	Lowered mast height	Free lift	Capacity (t)	Capacity (t)
		h ₁	h ₃	h ₃ +h ₁₃	h ₄	h ₂	(t) c=600 mm	(t) c=600 mm
Simplex	mm	2,080	1,610	1,650	2,250	1,560	1.6	2.0
Duplex	mm	1,955	2,760	2,800	3,435	1,410 *	1.6	2.0
	mm	2,105	3,060	3,100	3,730	1,560 *	1.6	2.0
	mm	2,360	3,560	3,600	4,230	1,810*	1.3	1.8
Triplex GAL	mm	1,860	3,560	3,900	4,500	1,310	1.1	1.6
	mm	1,960	4,160	4,200	4,800	1,410	1.0	1.5
	mm	2,110	4,610	4,610	5,250	1,560	0.90	1.4
	mm	2,360	5,360	5,400	6,000	1,810	0.60	1.0

* optional

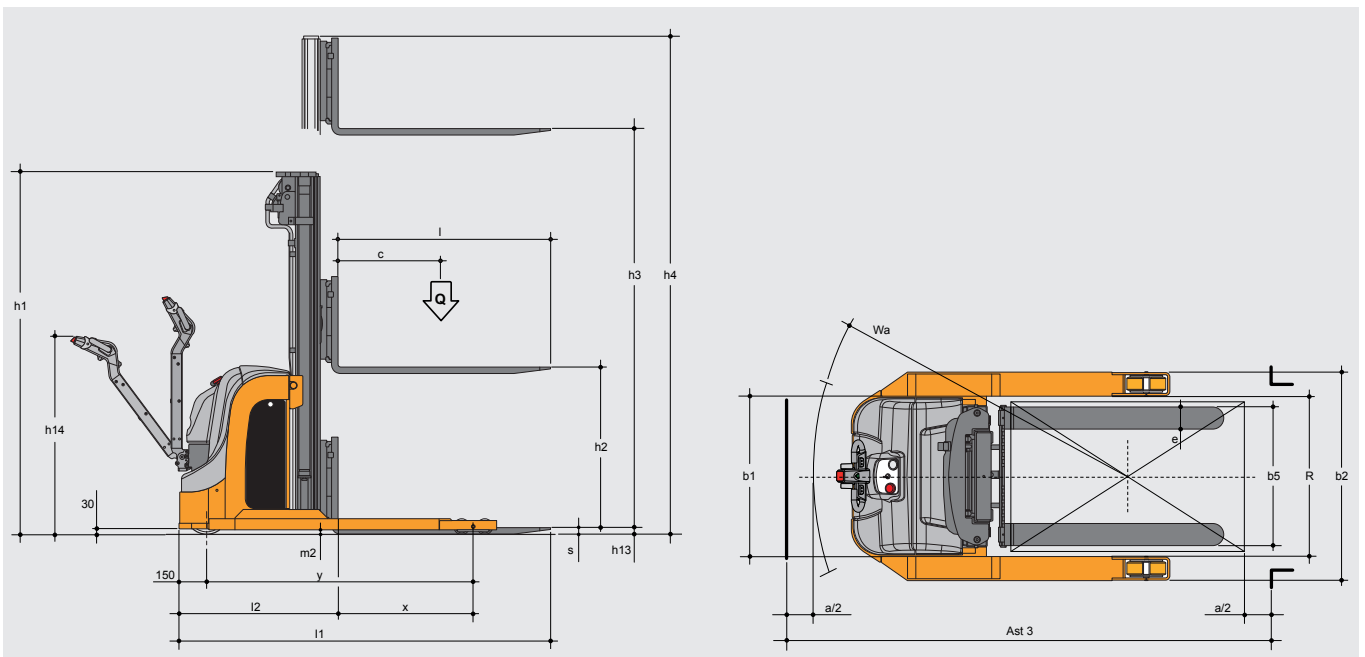

Characteristics	1.1	Manufacturer			OMG S.r.l.			
	1.2	Model			716 BLK ac	720 BLK ac		
		Execution						
	1.3	Operation			Electric			
	1.4	Operator position			at ground level			
	1.5	Capacity	Q	t	1.6	2.0		
		Mast lift capacity	Q	t	/	/		
		Forks lift capacity	Q	t	/	/		
		Forks + mast lift capacity	Q	t	/	/		
	1.6	Load centre of gravity	c	mm	600			
1.8	Load distance	x	mm	714	674			
1.9	Wheel centre distance	y	mm	1,443				
Weights	2.1	Truck weight incl. battery (see line 6.5)			kg	1,350	1,450	
	2.2	Weight on axis with front / rear load			kg	1,044 / 1,912	1,130 / 2,320	
	2.3	Weight on axis without front / rear load			kg	920 / 430	990 / 460	
Wheels Frame	3.1	Wheels and tyres			polyurethane			
	3.2	Front wheel size		mm	85	150		
	3.3	Rear wheels size		mm	230			
	3.4	Stabiliser wheels size		mm	/			
	3.5	Number of front / rear wheels (x = drive)			no.	1x / 4	1x / 2	
	3.6	Front track	b10	mm				
	3.7	Rear track	b11	mm	996			
Base dimensions	4.2	Lowered mast height			h1	mm	2,360	
	4.3	Free lift			h2	mm	1,810	
	4.4	Forks lifting stroke			h3	mm	3,510	
	4.5	Extended mast height			h4	mm	4,195	
	4.6	Initial lift			h5	mm	/	
	4.9	Tiller height in min. /max. driving position			h14	mm	740 / 1,300	
	4.15	Forks lowered height			h13	mm	40	
	4.19	Overall length			l1	mm	2,034	2,062
	4.20	Length including forks heel			l2	m	884	935
	4.21	Overall width	R/b1/ b2	mm	880/880/1,140	1,300/880/1,560		
	4.22	Forks size	s/e/l	mm	40 / 100 / 1,150			
	4.25	Width over forks	b5	mm	750			
	4.32	Clearance at mid stroke	m2	mm	25			
	4.33	Working aisle width with 1000 x 1200 transversal pallet	Ast	mm	2,532	2,532		
4.34	Working aisle width with 800 x 1200 longitudinal pallet	Ast	mm	2,462	2,483			
4.35	Turning radius	Wa	mm	1,660				
Performance	5.1	Speed with / without load			km/h	5.8 / 6		
	5.2	Lifting speed with / without load			m/s	0.14 / 0.18		
	5.3	Lowering speed with/without load			m/s	0.38 / 0.30		
	5.8	Max. feasible gradient with / without load			%	6 / 10		
	5.10	Service brake			Electromagnetic			
Electric motors	6.1	Traction motor, 60 min performance with S2			kW	1.2		
	6.2	Lift motor, 15% performance with S3			kW	3		
	6.3	Battery as per DIN 43531 / 35 / 36 A, B, C, no			DIN 43531			
	6.4	K5 battery voltage, nominal capacity			V/Ah	24 / 270 -345*-375*	24 / 345 -375*	
	6.5	Battery weight			kg	230		
	6.6	Power consumption as per VDI cycle			kW/h	1.25		
Miscellaneous	8.1	Type of electronic system			ac			
	8.4	Noise threshold as per EN 12 053			dB(A)	< 70		
							* optional	

Technical data sheet referring to pallet truck in standard version; data determined in compliance with VDI 2198. These values may differ if your product is fitted with other types of wheels and tires, supports and accessories. All data and images herein are indicative, OMG S.r.l.reserves the right to modify the documentation without prior notice.