

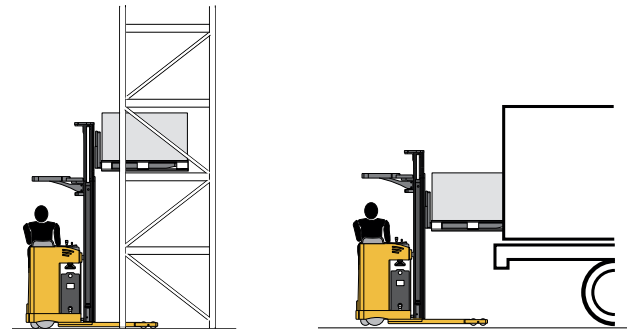

## Forklift truck with operator seat ideal for horizontal and vertical load handling over long distances



The Modus US ac forklift trucks with operator seat and servo-assisted steering wheel are ideal for horizontal and vertical load handling over long distances. The high-capacity battery ensures long battery life. High visibility mast with lift capacity between 1,560 mm and 5,310 mm. They are characterised by compact size, high manoeuvrability and are suitable for all sectors.

### Frame

Made of bended sheet metal to minimise any tensions induced by welds, ensuring maximum stability and best mechanical resistance under any conditions of transport and storage. The configuration with four support points provides maximum stability. The battery compartment cover is hinged, facilitating battery top-up and daily and periodical maintenance operations. Particular attention was paid to simplify the access to mechanical parts so as to minimise the routine maintenance costs.

### Masts

The OMG masts are made of cold extruded profiles, ensuring high resistance to bending and twisting. The lift cylinders are installed outside of the mast profiles and the chains are protected to ensure perfect visibility and

maximum safety for the operator. Available in simplex, duplex and triplex version with wide free lift. The mast comes with standard tilt function that facilitates load picking and storage operations.

### Hydraulic functions

The 4kW powerful and silent lift motor with high torque ration offers high performance with low power consumption. The pumps are highly efficient and very quiet.

### Drive

Powerful and reliable AC traction motor, capable of meeting even the most demanding requests in terms of performance, under any conditions.

## Electronic system

The machine is fitted with AC control with energy recovery, that can be enabled by:

- releasing the accelerator pedal;
- reversing the running direction

From this control, the operator can manage all truck's functions and carry out unlimited adjustments for performance optimisation, adapting the machine to any application, while ensuring silent operation and low power consumption at the same time.

## Comfort when picking and storing loads

The configuration with four support points provides optimal lateral stability, ensuring maximum safety and comfort during load picking and storage. The lifting, lowering and shifting levers ensure precise and smooth load lifting and lowering. The hydraulic motor with fluid adjustment system reduces the noise, ensuring at the same time smooth and precise load lifting. Enhanced lifting and lowering speed for faster operations. Side cylinders fitted with silent blocks to prevent any kickbacks that might affect the stability of the load during forks lowering.

## Operator's compartment

- comfortable adjustable seat;
- non-slip footrest;
- small steering wheel;
- low step height for easy access.

## Operation ensured in any conditions

The self-levelling axle ensure maximum grip on all surfaces, even when the truck is loaded.

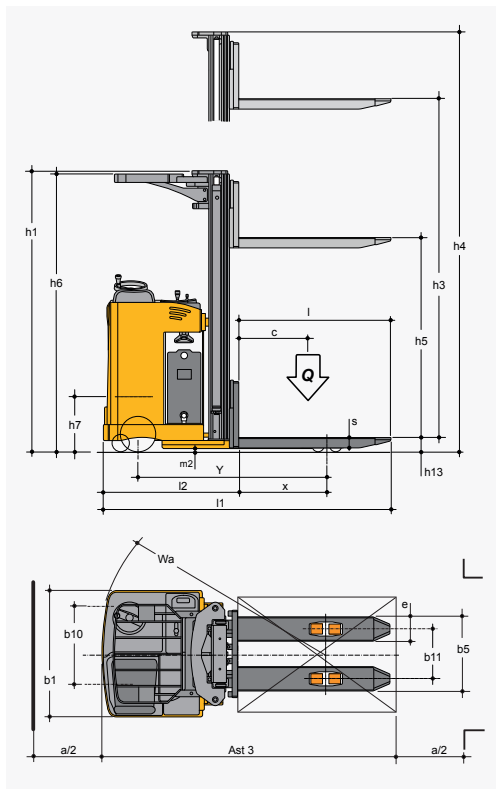

total free lift for duplex column	o	automatic battery filling system	o
total free lift for triplex column	o	electronic braking system	s
single roller for lateral battery extraction	o	electronic speed control	s
double roller for lateral battery extraction	o	electromagnetic parking brake	s
setup for cold store	o	battery level indicator-timer	s
s=standard		o=optional	

h3		h1	h4	h5	(Q) t
1,560 sx	mm	2,090	2,250	1,565	1.5
3,010 dx	mm	2,120	3,730	1,525 *	1.5
3,510 dx	mm	2,370	4,230	1,775 *	1.3
4,560 tx	mm	2,120	5,280	1,525 *	0.9
5,310 tx	mm	2,370	6,020	1,775 *	0.7
(*) optional					

Characteristics	1.1	Manufacturer			OMG S.r.l. Single member company	
	1.2	Model			MODUS US ac	
	1.3	Powertrain : E (electric)			E	
	1.4	Type of steering : T (tiller) S (steering wheel) A (walk behind) P (stand-on) R (seated)			S / R	
	1.5	Capacity	Q	t	1.5	
	1.6	Center of mass	c	mm	600	
	1.8	Load distance from front axle	X	mm	672	
	1.9	Wheel centre distance	Y	mm	1,427	
	Weights	2.1	Truck weight (with battery)		kg	1,810
2.2		Load on wheels (with load)	front/rear	kg	1,860 / 1,300	
2.3		Load on wheels (empty)	front/rear	kg	1,246 / 564	
Wheels - Frame	3.1	Tyres and wheels : pit (polyurethane) vlk (vulkollan)			pit	
	3.2	Front wheels size		mm	245	
	3.3	Rear wheels size		mm	85	
	3.4	Stabiliser wheels size		mm	150	
	3.5	Wheels number : front / rear ( x = drive )			2 + 1x / 4	
	3.6	Front track	b 10	mm	630	
	3.7	Rear track	b 11	mm	380	
Dimensions	4.2	Lowered mast height	h1	mm	2,120	
	4.3	Free lift	h5	mm	/	
	4.4	Lifting height	h3	mm	4,560	
	4.5	Extended mast height	h4	mm	5,280	
	4.7	Overhead guard height	h6	mm	2,080	
	4.8	Platform/seat height from the ground	h7	mm	850	
	4.15	Forks lowered height	h13	mm	90	
	4.19	Overall length	l1	mm	2,166	
	4.20	Length including fork plates	l2	mm	1,006	
	4.21	Overall width	b1 / b2	mm	950	
	4.22	Forks size	s / e / l	mm	80 / 180 / 1,150	
	4.24	Forks support plate width	b3	mm		
	4.25	Width over forks	b5	mm	560	
	4.32	Clearance at mid stroke	with load	m2	mm	50
	4.33	Working aisle with 1000 x 1200 pallet and 1200 forking	Ast3	mm		
4.34	Working aisle with 800 x 1200 pallet and 800 forking	Ast3	mm	2,545		
4.35	Turning radius	Wa	mm	1,700		
Performance	5.1	Translation speed	with load / empty	km / h	8 / 9.5	
	5.2	Lifting speed	with load / empty	m / s	0.18 / 0.25	
	5.3	Lowering speed	with load / empty	m / s	0.4	
	5.7	Feasible gradient ( S2 30 min )		%		
	5.8	Max feasible gradient ( S2 5 min )		%	10 / 15	
	5.10	Service brake M (mechanical) I (hydraulic) IV (reverse)			IV	
Motor	6.1	Traction motor, power S2 60 min		kW	2.6	
	6.2	Lift motor, power S3 15%		kW	4	
	6.3	Battery as per DIN 43531 / 35 / 36 A, B, C, no			DIN	
	6.4	K5 battery voltage, capacity		V / Ah	24 / 500	
	6.5	Battery weight ( ± 5 % )		kg	370	
Other	8.1	Start control type			AC	
	8.4	Noise level at operator's station		dB (A)	< 70	
technical data determined in compliance with VDI 2198					DS.076IT.REV.00	
All data and images herein are indicative, OMG S.r.l. Single member company reserves the right to modify the documentation without prior notice.						